

MINI DOME NETWORK CAMERA



Experience optimal security with the D2FDA28IP5MP-AI network camera. Boasting an impressive 5 MP resolution and a precisely designed 2.8mm lens, this camera ensures crystal-clear images capturing every detail with exceptional clarity. The surveillance system setup is simplified through a seamless P2P connection, allowing you to start quickly. What makes this camera unique is its comprehensive set of features, including in/out alarm options and audio capabilities. Equipped with advanced artificial intelligence, it intelligently detects and analyzes movements, objects, and sounds, providing accurate alerts and instant notifications. Stay connected and informed wherever you are; ensuring the security of your premises has never been easier.



D2FDA28IP5MP-AI



5MP RESOLUTION



2.8MM LENS



IR UP TO 30M



TRUE WDR



IMPACT RESISTANT



WATERPROOF AND
DUST-TIGHT



MICRO SD CARD SLOT UP TO 256 GB



VIDEO

IMAGING DEVICE	1/2.7"
EFFECTIVE PIXELS	5MP 2592(H)×1944(V)
SCANNING SYSTEM	Progressive CMOS
MIN. ILLUMINATION	Color 0.05lux @ F1.2(AGC ON) ; B/W 0 lux @ IR ON

LENS TYPE

FOCAL LENGTH (ZOOM RATIO)	2.8 mm
MAX. APERTURE RATIO	F No. 1.6
ANGULAR FIELD OF VIEW	Horizontal: 97°, Vertical: 70°, Diagonal: 128°
MIN. OBJECT DISTANCE	1.8m
LENS TYPE	Fixed M12

OPERATIONAL

IR VIEWABLE LENGTH	Up to 30m
CAMERA TITLE	On/Off
DAY & NIGHT	IR cut filter with auto switch (Day/Night/Auto/Image/Schedule)
BACKLIGHT COMPENSATION	Off/On (5 Zone)
WIDE DYNAMIC RANGE	WDR
DIGITAL NOISE REDUCTION	3D DNR
MOTION DETECTION	Off/On (8 Level)
PRIVACY MASKING	Off/On (4 Zone, Rectangle)
GAIN CONTROL	Auto
WHITE BALANCE	Auto/Manual
ELECTRONIC SHUTTER SPEED	1/5 ~ 1/20000s
FLIP / MIRROR	Flip/Rotation
ON-BOARD STORAGE	Micro SD slot, up to 256GB
ALARM	Yes
AUDIO	Yes
HARDWARE RESET	Yes
SMART FEATURES	Perimeter Intrusion Detection (PID), Face Detection (FD), Stationary Object Detection (SOD), Crowd Density Detection (CD), Human&Vehicle Detection (PD&VD), Line Crossing Detection (LCD), Queue Length Detection (QD), Heat Map (HM), Cross Counting (CC)

NETWORK

ETHERNET	RJ45(10/100BASE-T)
VIDEO COMPRESSION FORMAT	H.265/H.264
RESOLUTION	Mainstream@30fps 5MP(2592×1944),4MP(2592×1520) 3MP(2304×1296),1080P(1920×1080) 960P(1280×960),720P(1280×720) Substream@30fps 720P(1280×720),VGA(640×480),QVGA(320×240) Mobilestream@30fps VGA(640×480), QVGA (320×240)
VIDEO QUALITY ADJUSTMENT	8Kbps ~ 8Mbps
BITRATE CONTROL METHOD	CBR/VBR
STREAMING CAPABILITY	Triple-Stream(Main/Sub/Mobile)
IP	IPv4
PROTOCOL	TCP/IP,HTTP,DHCP,DNS,DDNS,RTP/RTSP,SMTP,NTP,UPnP,SNMP,HTTPS,FTP
SECURITY	IP address filter:complicated password: Authenticated username and password
STREAMING METHOD	Unicast/Multicast
MAX. USER ACCESS	Max 7 (admin+user)
APPLICATION PROGRAMMING INTERFACE	ONVIF(Profile S/G/T)
COMPATIBLE WEB BROWSERS	IE8,9,10,11, Chrome 44/lower, Firefox 51/lower, Safari 11/lower

ENVIRONMENTAL

OPERATING CONDITIONS	-30°~+55°C/less than ≤ 95% RH
STORAGE CONDITIONS	-30°~+60°C/less than ≤ 95% RH
INGRESS PROTECTION	IP67
PROTECTION RATING	IK10
INPUT VOLTAGE / CURRENT	D12V/POE(IEEE802.3af)
POWER CONSUMPTION (IR OFF)	2.5W/3.5W
POWER CONSUMPTION (IR ON)	4W/5.5W
COLOR / MATERIAL	White/Metal
DIMENSION (WXHXD)	Ø115x90.1mm
WEIGHT	appr 570g



DIMENSIONS

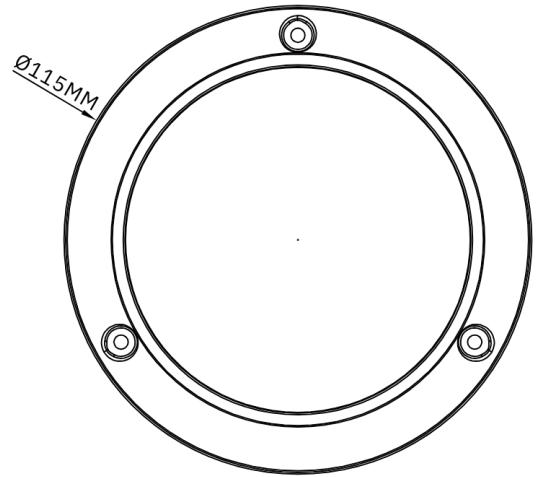
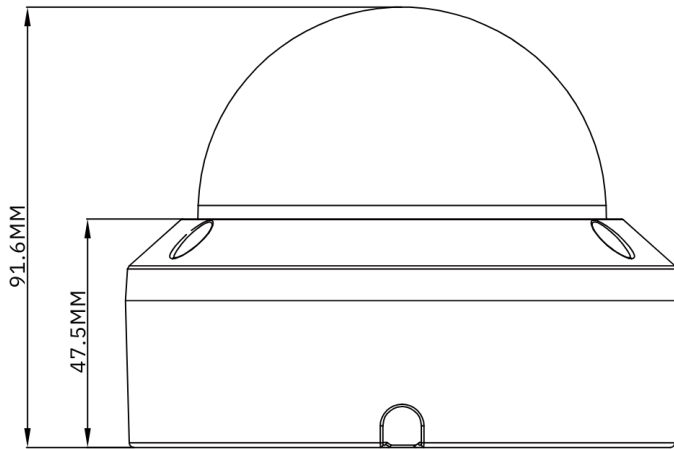

ACCESSORIES



D2BASE1
JUNCTION BOX

OR



WMB2
WALLMOUNT BRACKET



D2BASE1-G
PENDANT

+



WMB6
WALLMOUNT

OR



CMB6
CEILING MOUNT BRACKET



PMB6
POLE MOUNT BRACKET

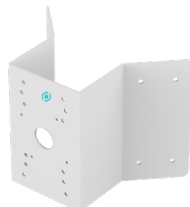

COMB6
CORNER MOUNT BRACKET



CMB6-EXT-120
EXTENDABLE CEILING MOUNT BRACKET

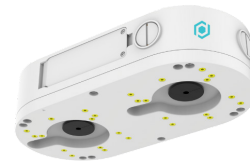

DBASEC
DOUBLE JUNCTION BOX



DCMB2
RECESSED BRACKET