

MODEL #

D6Z2812IP8MP-AI



DOME NETWORK CAMERA



8MP
RESOLUTION



8MP
Resolution

2.7-13.5MM
Motorized Lens



IR Up to 30M

Alarm
In/Out



Audio
In/Out

IK10 Impact
Resistant



IP67
Dustproof
& Water-Resistant

Micro SD Card
Slot up to 1TB

Introducing the **D6Z2812IP8MP-AI**, a revolutionary surveillance camera that redefines security standards. Boasting an impressive 4K resolution, it captures sharp details, leaving nothing unnoticed. With a 30-meter infrared range for 24/7 monitoring and a motorized 2.8-12 mm lens allowing flexible adjustments in low light, this camera excels. Receive instant notifications through alarm input/outputs and enjoy clear two-way audio communication for toptier surveillance. Opt for security excellence with the D6Z2812IP8MP-AI, ensuring uncompromising safety and cutting-edge technology in a compact, reliable package, setting a new benchmark in advanced surveillance solutions.



VIDEO

Imaging Device	1/2.8"
Effective Pixels	8MP 3840(H)×2160(V)
Scanning System	Progressive CMOS
Min. Illumination	Color 0.1lux @ F1.2(AGC ON) ; B/W 0 lux @ IR ON

LENS TYPE

Focal Length (Zoom Ratio)	2.7-13.5mm
Max. Aperture Ratio	F No. 1.83 (W) ~ 3.32(T)
Angular Field of View	Horizontal: 33 ~111°, Vertical: 18 ~ 57°, Diagonal: 37 ~ 134°
Min. Object Distance	0.8m(W) ~ 1m(T)
Lens Type	Motorized(Ø14)

OPERATIONAL

IR viewable length	Up to 30m
Camera Title	Show/Hide
Day & Night	IR cut filter with auto switch (Day/Night/Auto/Image/Schedule)
Backlight Compensation	Off/On (5 Zones)
Wide dynamic range	WDR
Digital Noise Reduction	3D DNR
Motion Detection	Off/On (8 Levels)
Privacy Masking	Off/On (4 Zones, Rectangle)
Gain Control	Auto
White Balance	Auto/Manual
Electronic Shutter Speed	1/5 ~ 1/20000s
Image Setting	Flip/Corridor/Rotation
On-board Storage	Micro SD slot, up to 1TB
Alarm	1 input, 1 output
Audio	1 input (RCA), 1 output (RCA)
Hardware Reset	Yes
Smart Features	Perimeter Intrusion Detection (PID), Line Crossing Detection (LCD), Stationary Object Detection (SOD), Human&Vehicle Detection (PD&VD), Face Detection (FD), Cross Counting (CC), Crowd Density Detection (CD), Queue Length Detection (QD), Heat Map (HM).

NETWORK

Ethernet	RJ45(10/100BASE-T)
Video Compression Format	H.265/H.264
Resolution	Mainstream @30fps 8MP(3840x2160), 5MP(2592x1944,3072x1728), 4MP(2592x1520), 3MP(2304x1296), 1080P(1920x1080), 960P(1280*960), 720P(1280x720) Substream @30fps 720P(1280x720),VGA(640x480),QVGA(320x240) Mobile Stream @30fps VGA(640x480), QVGA(320x240)
Max. Framerate	50Hz:25fps@8MP,5MP,4MP,3MP,2MP,960P, 720P,VGA,QVGA 60Hz:30fps@8MP,5MP,4MP,3MP,2MP,960P, 720P,VGA,QVGA
Video Quality Adjustment	8Kbps ~ 16Mbps
Bitrate Control Method	CBR/VBR
Streaming Capability	Triple-Stream(Main/Sub/Mobile)
IP	IPv4
Protocol	TCP/IP,HTTP,DHCP,DNS,DDNS,RTP/RTSP, SMTP,NTP,UPnP,SNMP,HTTPS,FTP
Security	IP address filter; complicated password; Authenticated username and password
Streaming Method	Unicast/Multicast
Max. User Access	Max 7 (admin+user)
App Programming Interface	ONVIF(Profile S/G/T)
Compatible Web Browsers	IE8,9,10,11, Chrome 44/lower, Firefox 51/ lower, Safari 11/lower

GENERAL

Operating Conditions	-30~ +55°C/less than ≤ 95% RH
Storage Conditions	-30~+60°C/less than ≤ 95% RH
Ingress Protection	IP67
Protection rating	IK10
Input Voltage/ Current	D12V/POE(IEEE802.3af)
Power Consumption (IR OFF)	3W/4W
Power Consumption (IR ON)	5W/7W
Color/Material	White/Metal
Dimensions (HXWXD)	Ø148.7x109mm
Weight	appr 960g

DIMENSIONS

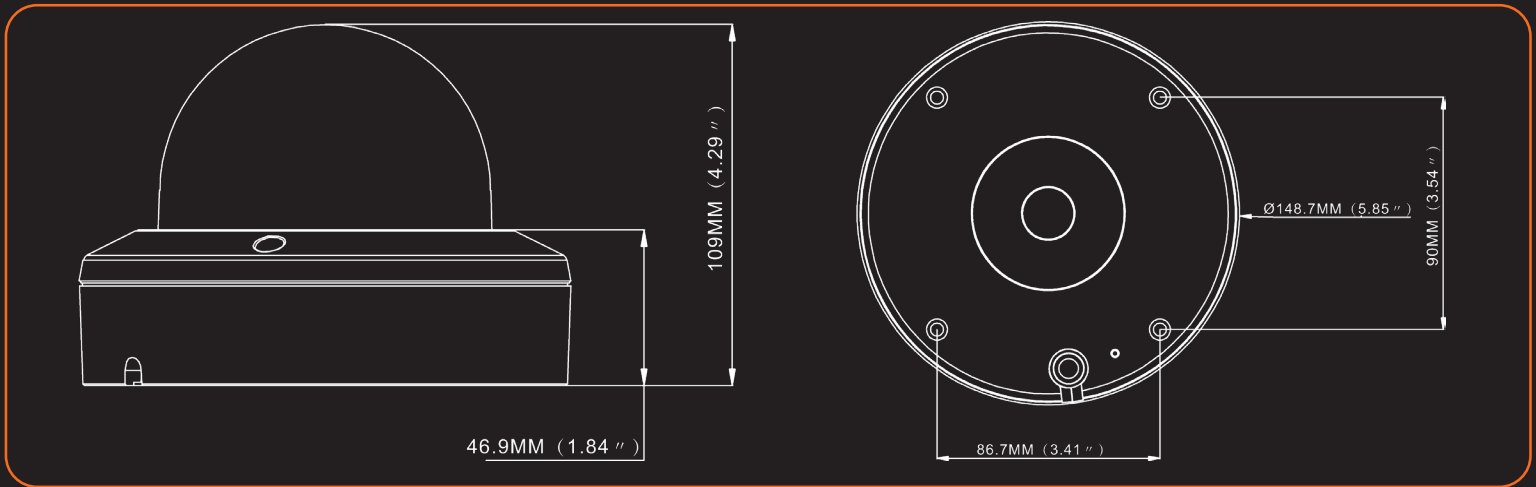

COMPATIBLE ACCESSORIES

CEILING MOUNT SOLUTION



CMB6-G
CEILING MOUNT

EB3BASE3-G
PENDANT

CORNER MOUNT SOLUTION

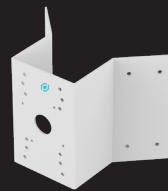

COMB6
CORNER MOUNT BRACKET

POLE MOUNT SOLUTION



PMB6
POLE MOUNT BRACKET

WALL MOUNT SOLUTION



WMB5
WALLMOUNT BRACKET

WMB6
WALLMOUNT BRACKET

EB3BASE3-G
PENDANT

JUNCTION BOX



EB3BASE3
JUNCTION BOX

DOWNLOAD THE OV CONNECT APP

