

MODEL #

D6Z2812IP5MP-AI-B

CTAVUE®



DOME NETWORK CAMERA

Onvif® | GMST | NDAA Compliant | AI



5MP
RESOLUTION



5MP
Resolution

2.7-13.5MM
Motorized Lens



IR Up to 30M

Alarm
In/Out



Audio
In/Out

IK10 Impact
Resistant



IP67
Dustproof
& Water-Resistant

Micro SD Card
Slot up to 1TB

Discover the D6Z2812IP5MP-AI-B security camera, a true gem in surveillance. Its 5 MP resolution provides exceptional clarity, capturing every detail with remarkable sharpness. The P2P connection ensures easy remote access, allowing flexible monitoring of your property from anywhere. Equipped with alarm input/output and audio input/output features, this camera offers a comprehensive security solution. Instant notifications on your mobile device keep you informed in real-time of any suspicious activities. Harness the integrated artificial intelligence for efficient identification and response to potential threats. Choose this 5 MP camera to invest in a higher level of security, combining advanced technology and peace of mind.



VIDEO

Imaging Device	1/2.7"
Effective Pixels	5MP 2880(H) x 1620(V)
Scanning System	Progressive CMOS
Min. Illumination	Color 0.05lux @ F1.2(AGC ON) ; B/W 0 lux @ IR ON

LENS TYPE

Focal Length (Zoom Ratio)	2.7-13.5mm
Max. Aperture Ratio	F No. 1.83 (W) ~ 3.32(T)
Angular Field of View	Horizontal: 31 ~102°, Vertical: 23 ~ 73°, Diagonal: 38 ~ 138°
Min. Object Distance	0.3m~INF
Lens Type	Motorized(Ø14)

OPERATIONAL

IR viewable length	Up to 30m
Camera Title	Show/Hide
Day & Night	IR cut filter with auto switch (Day/Night/Auto/ Image/Schedule)
Backlight Compensation	Off/On (5 Zones)
Wide dynamic range	WDR
Digital Noise Reduction	3D DNR
Motion Detection	Off/On (8 Levels)
Privacy Masking	Off/On (4 Zones, Rectangle)
Gain Control	Auto
White Balance	Auto/Manual
Electronic Shutter Speed	1/5 ~ 1/20000s
Image Setting	Flip/Rotation
On-board Storage	Micro SD slot, up to 1TB
Alarm	1 input, 1 output
Audio	1 input (RCA), 1 output (RCA)
Hardware Reset	Yes
Smart Features	Perimeter Intrusion Detection (PID), Line Crossing Detection (LCD), Stationary Object Detection (SOD), Human&Vehicle Detection (PD&VD), Face Detection (FD), Cross Counting (CC), Crowd Density Detection (CD), Queue Length Detection (QD), Heat Map (HM)

NETWORK

Ethernet	RJ45(10/100BASE-T)
Video Compression Format	H.265/H.264
Resolution	Mainstream @30fps 5MP(2880x1620), 4MP(2560x1440) 3MP(2304x1296), 1080P(1920x1080), 720P(1280x720) Substream @30fps 720P(1280x720),VGA(640x480),QVGA(320x240) Mobile Stream @30fps VGA(640x480), QVGA(320x240)
Video Quality Adjustment	8Kbps ~ 8Mbps
Bitrate Control Method	CBR/VBR
Streaming Capability	Triple-Stream(Main/Sub/Mobile)
IP	IPV4
Protocol	TCP/IP,HTTP,DHCP,DNS,DDNS,RTP/RTSP, SMTP,NTP,UPnP,SNMP,HTTPS,FTP
Security	IP address filter; complicated password; Authenticated username and password
Streaming Method	Unicast/Multicast
Max. User Access	Max 7 (admin+user)
App Programming Interface	ONVIF(Profile S/G/T)
Compatible Web Browsers	IE8,9,10,11, Chrome 44/lower, Firefox 51/ lower, Safari 11/lower

GENERAL

Operating Conditions	-30~+55°C/less than ≤ 95% RH
Storage Conditions	-30~+60°C/less than ≤ 95% RH
Ingress Protection	IP67
Protection Rating	IK10
Input Voltage/ Current	D12V/POE(IEEE802.3af)
Power Consumption (IR OFF)	3.5W/4.5W
Power Consumption (IR ON)	5.5W/7.5W
Color/Material	Black/Metal
Dimensions (HXWXD)	Ø148.7x109mm
Weight	appr 960g

DIMENSIONS

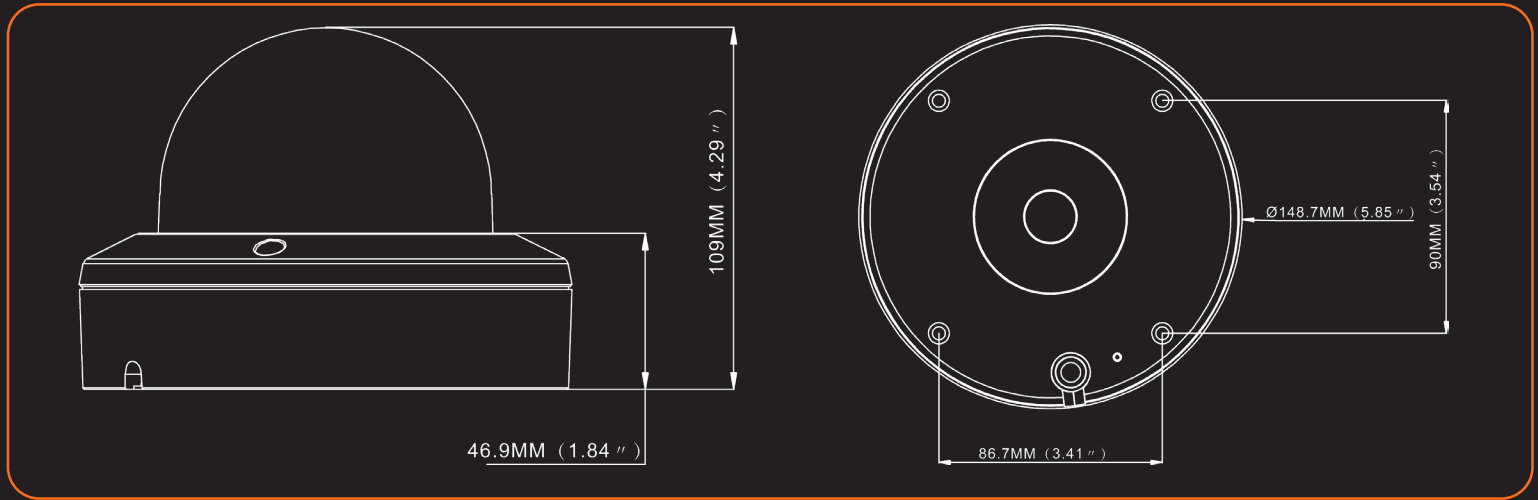

COMPATIBLE ACCESSORIES

WALL MOUNT SOLUTION



 **WMB5-B**
WALLMOUNT BRACKET

CORNER MOUNT SOLUTION

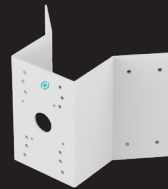

 **COMB6**
CORNER MOUNT BRACKET

POLE MOUNT SOLUTION



 **PMB6**
POLE MOUNT BRACKET

JUNCTION BOX



 **EB3BASE3-B**
JUNCTION BOX

DOWNLOAD THE OV CONNECT APP

