

X SERIES NETWORK CAMERA



Introducing the XT3ZTV2812IP8MP-AI, an advanced security camera committed to ensuring the flawless protection of your property. With an impressive 8 MP HD resolution, this camera captures crisp images both day and night, facilitated by a remarkable 45-meter infrared (IR) range and a motorized lens of 2.8-12 mm. The incorporation of red and blue deterrent lights enhances overall security, while the alarm input/output feature allows for immediate alerts. Additionally, the two-way audio function with microphone support ensures clear communication. All these capabilities are seamlessly integrated into a compact and harmonious design, providing discreet yet effective protection in any environment. Choose the XT3ZTV2812IP8MP-AI for advanced security solutions tailored to meet your specific needs.



XT3ZTV2812IP8MP-AI



8MP RESOLUTION



IR UP TO 45M



2.8-12MM
MOTORIZED LENS



DETERRENCE LIGHTS
AND SIREN



ALARM/AUDIO
IN/OUT



SEE IN COLOR AT NIGHT



WATERPROOF &
DUST-TIGHT



TWO-WAY
COMMUNICATION



MICRO SD CARD
SLOT UP TO 256 GB



VIDEO

IMAGING DEVICE	1/2.8"
EFFECTIVE PIXELS	8MP 3840(H)*2160(V)
SCANNING SYSTEM	Progressive CMOS
MIN. ILLUMINATION	Color 0.007lux @ F1.0(AGC ON) ; B/W 0 lux @ IR ON

LENS

FOCAL LENGTH (ZOOM RATIO)	2.8-12mm
MAX. APERTURE RATIO	F No. 1.2
ANGULAR FIELD OF VIEW	H:107(W)-34(T)° V:56(W)-19(T)° D: 129(W)-39(T)°
MIN. OBJECT DISTANCE	1.5m
LENS TYPE	Motorized Ø16.7

OPERATIONAL

IR LED	2
WARMLIGHT	2
RED BLUE LIGHT	2 (1Red & 1 Blue)
IR VIEWABLE LENGTH	Up to 45m
WARMLIGHT VIEWABLE LENGTH	Up to 25m
TYPE OF COMPLEMENTARY LIGHT	Default warm light, switchable infrared light
MOTION DETECTION	Off/On (8 Level)
WIDE DYNAMIC RANGE	WDR
DIGITAL NOISE REDUCTION	3D DNR
IMAGE SETTING	Day&Night Mode/Full Color Mode/Schedule
WHITE BALANCE	Auto/Manual
ELECTRONIC SHUTTER SPEED	1/5 ~ 1/20000s
ON-BOARD STORAGE	Micro SD slot, up to 256GB
ALARM	1 input, 1 output
AUDIO	Built-in microphone & Speaker; 1 input (RCA), 1 output (RCA)
CUSTOM VOICE	Yes
HARDWARE RESET	Yes
SMART FEATURE	Rare Sound Detection (SD) , Perimeter Intrusion Detection (PID), Face Detection (FD), Stationary Object Detection (SOD), Crowd Density Detection (CD), Human&Vehicle Detection (PD&VD), Line Crossing Detection (LCD), Queue Length Detection (QD), Heat Map (HM), Cross Counting (CC), License Plate Detection (LPD)

NETWORK

ETHERNET	RJ45(10/100BASE-T)
VIDEO COMPRESSION FORMAT	H.265/H.264
RESOLUTION	<p>Mainstream @30fps 8MP(3840x2160),5MP(2592x1944,3072x1728), 4MP(2592x1520), 3MP(2304x1296), 1080P(1920x1080), 960P(1280*960),720P(1280x720)</p> <p>Substream @30fps 720P(1280x720),VGA(640x480),QVGA(320x240)</p> <p>Mobile Stream @30fps VGA (640x480), QVGA (320x240)</p>
VIDEO QUALITY ADJUSTMENT	256Kbps ~ 16Mbps
BITRATE CONTROL METHOD	CBR/VBR
IP	IPv6
PROTOCOL	TCP/IP,HTTP,DHCP,DNS,DDNS,RTP/RTSP, SMTP,NTP,UPnP,SNMP,HTTPS,FTP
SECURITY	IP address filter:complicated password: Authenticated username and password
APPLICATION PROGRAMMING INTERFACE	ONVIF(Profile S/G/T)
WEB VIEWER	IE10/11, Safari V12.1 above, Firefox V.52 above Google chrome V.57 above, Edge V.79 above

GENERAL

OPERATING CONDITIONS	-35 ~ +60°C/less than ≤ 95% RH
INGRESS PROTECTION	IP67
INPUT VOLTAGE / CURRENT	D12V/POE(IEEE802.3af)
POWER CONSUMPTION	DC12V : max 6.9W; POE (48V): max 8.6W
COLOR/MATERIAL	White/Metal
DIMENSION (WXHXD)	Ø135x126.5mm
WEIGHT	Appr. 846g

DIMENSIONS

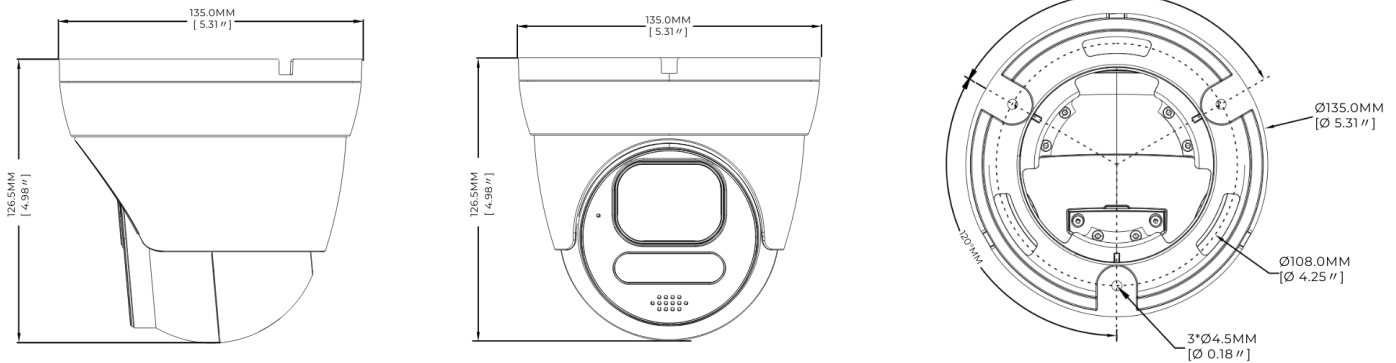

ACCESSORIES



EB3BASE3
JUNCTION BOX

OR



WMB5
WALLMOUNT BRACKET



EB3BASE3-G
PENDANT

+



WMB6
WALLMOUNT BRACKET

OR



CMB6-G
CEILING MOUNT BRACKET



PMB6
POLE MOUNT BRACKET

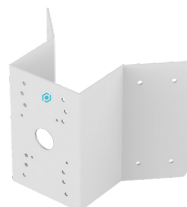

COMB6
CORNER MOUNT BRACKET



CMB6-EXT-150
EXTENDABLE CEILING MOUNT BRACKET

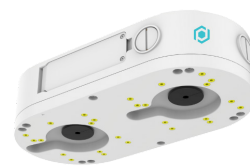

DBASEX
DOUBLE JUNCTION BOX



IPCOAX-300M
IP OVER COAX EXTENDER